

| Code | Type | Material | bearing | Life expectancy |
|-------|-------------------|----------|-------------|-----------------|
| ZHJ02 | Axial Fan DC type | PBT | double ball | 70000H(25°C) |

CE

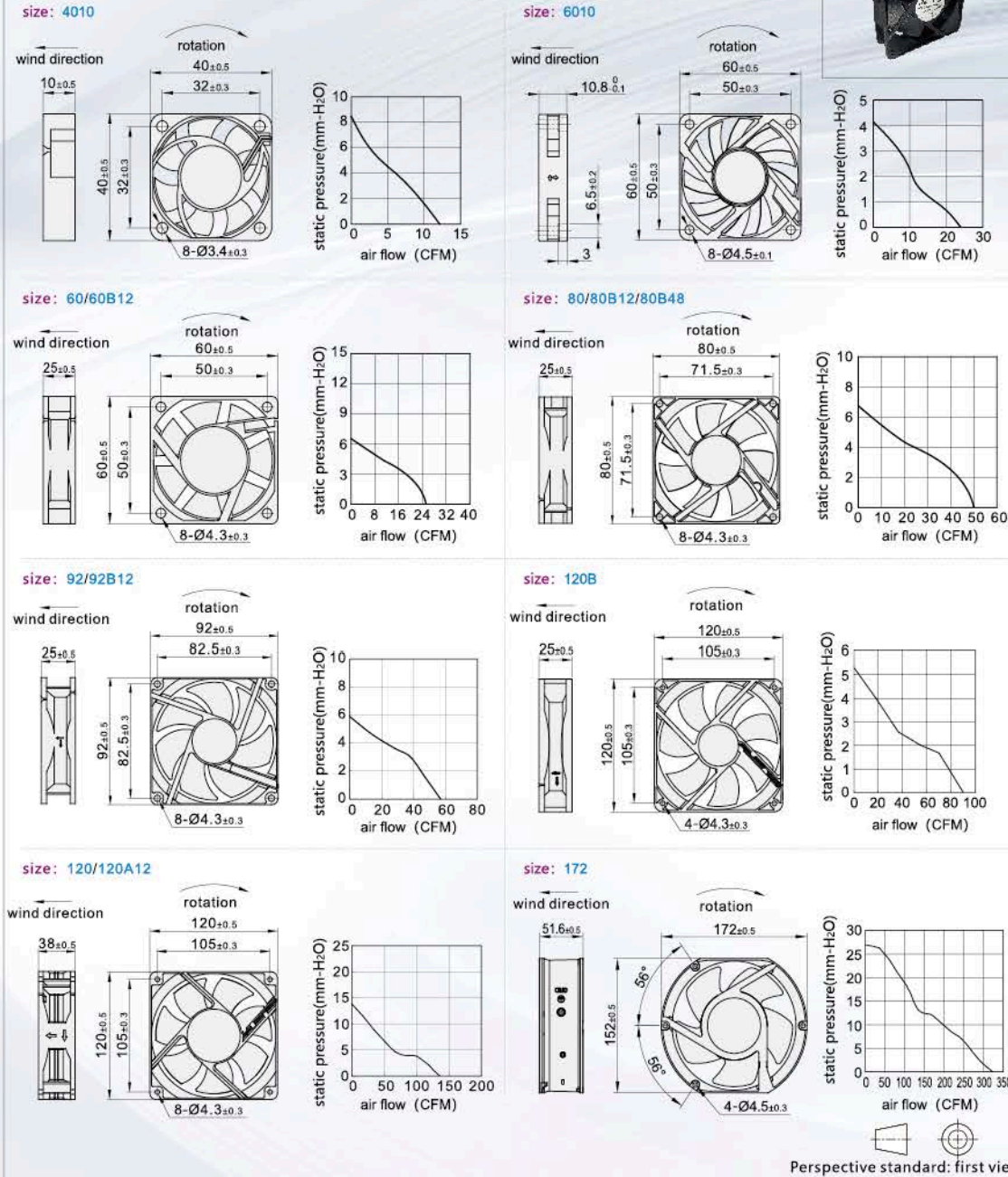

| Model Code | Dimension | Accessories | Length, width and height (mm) | Input Voltage | Current (A) | Rotational Speed (RPM) | Air volume (CFM) | Wind pressure (mm-H ₂ O) | Noise (Db[A]) | Weight (g) | |
|------------|-----------|-------------|-------------------------------|---------------|-------------|------------------------|------------------|-------------------------------------|---------------|------------|----|
| ZHJ02 | 4010 | | 60×60×25 | DC12V | 0.21 | 5000 | 25.6 | 6.5 | 40 | 60 | |
| ZHJ02 | 6010 | | 80×80×25 | | 0.35 | 4300 | 50.5 | 6.8 | 38 | 78 | |
| ZHJ02 | 92B12 | | 92×92×25 | | 0.35 | 3200 | 56.8 | 5.89 | 38 | 80 | |
| ZHJ02 | 120A12 | Iron Mesh | 120×120×38 | | 0.75 | 2900 | 123.2 | 11.3 | 44 | 260 | |
| ZHJ02 | 4010 | ZHJ42 | 40×40×10 | DC24V | 0.14 | 10000 | 12.23 | 8.43 | 39 | 20 | |
| ZHJ02 | 6010 | Filter mesh | 60×60×10.8 | | 0.09 | 5000 | 24.4 | 4.1 | 37 | 26 | |
| ZHJ02 | 60 | ZHJ41 | 60×60×25 | | 0.2 | 5000 | 25.6 | 6.5 | 40 | 57 | |
| ZHJ02 | 80 | or | 80×80×25 | | 0.23 | 4300 | 50.5 | 6.8 | 40 | 76 | |
| ZHJ02 | 92 | Blinds | 92×92×25 | | 0.15 | 3200 | 56.8 | 5.89 | 38 | 79 | |
| ZHJ02 | 120B | ZHJ43 | 120×120×25 | | 0.15 | 2500 | 90 | 5.3 | 36 | 152 | |
| ZHJ02 | 120 | | 120×120×38 | | 0.48 | 2900 | 123.2 | 11.3 | 44 | 260 | |
| ZHJ02 | 172 | | 172×152×51.6 | | 1.4 | 4400 | 323 | 26.9 | 63.5 | 610 | |
| ZHJ02 | 80B48 | | 80×80×25 | | DC48V | 0.13 | 4300 | 50.5 | 6.8 | 40 | 78 |

See P227 for details of applicable accessories iron mesh/filter, and P228 for details of louvers.

| Code | Type | Material | bearing | Flame retardant grade |
|-------|-------------------|----------|-------------|-----------------------|
| ZHJ06 | Axial Fan DC type | PBT | double ball | UL94V-0 |

CE

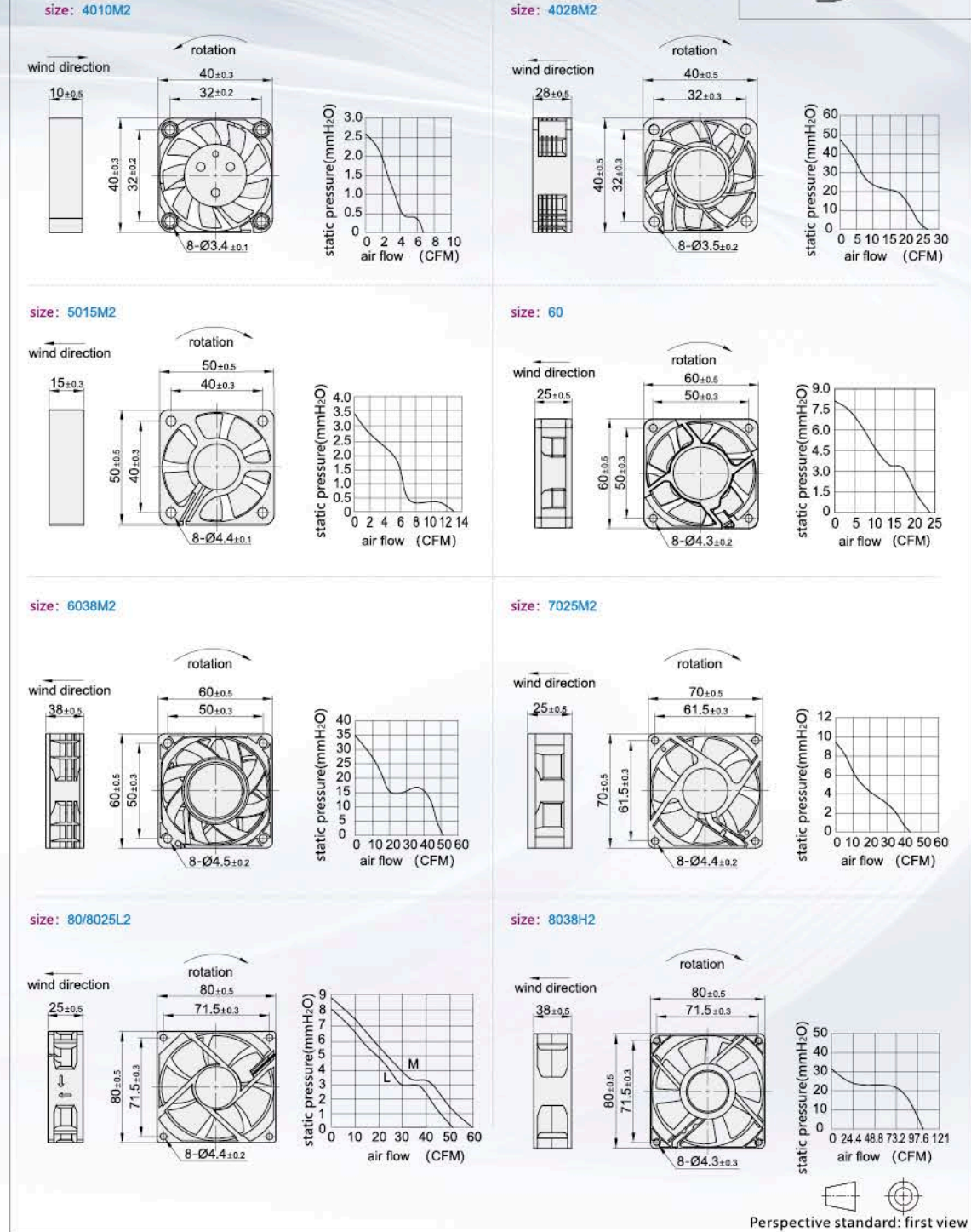

size: 92/9225L2

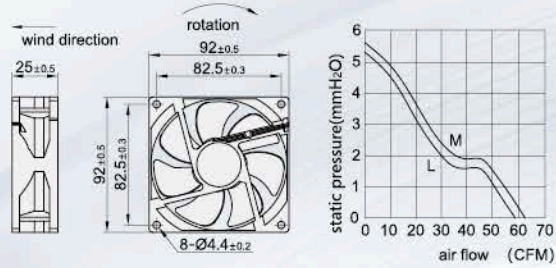

size: 120B

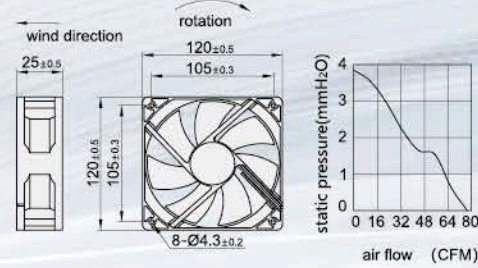

size: 120/12038L2/12038H2

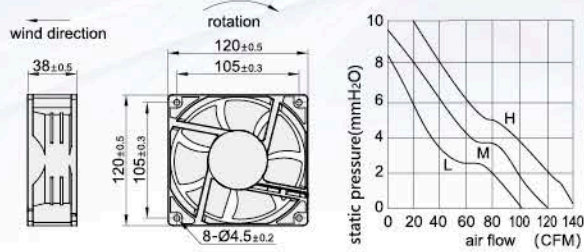

size: 17251M2

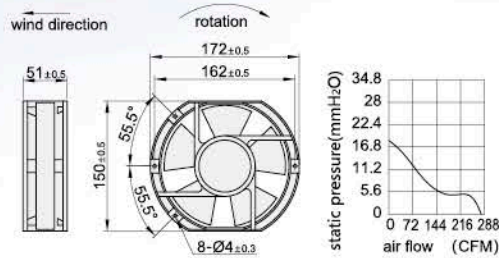

size: 20060M2

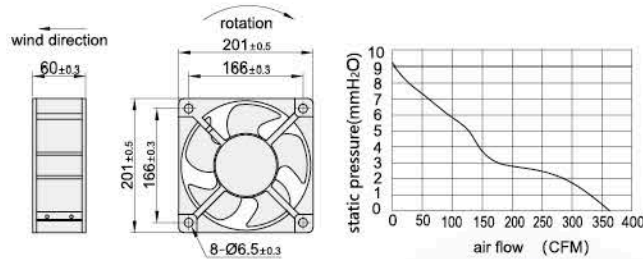

Perspective standard: first view

| Model | Length, width and height | Accessories | Rotational Speed Grade | Input Voltage | Current (A) | Rotational Speed (RPM) | Air volume (CFM) | Wind pressure (mm-H2O) | Noise (Db[A]) | Weight (g) |
|----------------|--------------------------|------------------------------|------------------------|---------------|-------------|------------------------|------------------|------------------------|---------------|------------|
| 4010M2 | 40×40×10 | | | | 0.06 | 6000 | 8 | 4.5 | 28 | 20 |
| 4028M2 | 40×40×28 | | | | 0.2 | 9000 | 15 | 8 | 39 | 46 |
| 5015M2 | 50×50×15 | | | | 0.08 | 5000 | 14 | 4.5 | 35 | 20 |
| 60 | 60×60×25 | | M | | 0.11 | 5000 | 21.45 | 7.3 | 43.78 | 60 |
| 6038M2 | 60×60×38 | | | | 0.3 | 8000 | 35 | 10 | 45 | 67 |
| 7025M2 | 70×70×25 | | | | 0.06 | 3000 | 25 | 4 | 29 | 60 |
| 8025L2 | 80×80×25 | | L | | 0.08 | 2000 | 28 | 3 | 28 | 79 |
| 80 | 80×80×25 | Iron mesh ZHJ42 | M | DC24V | 0.13 | 4300 | 52.69 | 7.48 | 48.95 | 75 |
| 8038H2 | 80×80×38 | Filter ZHJ41 or Blinds ZHJ43 | H | | 1 | 9000 | 96 | 31 | 58 | 170 |
| 9225L2 | 92×92×25 | | L | | 0.05 | 2200 | 33 | 1.7 | 30 | 88 |
| 92 | 92×92×25 | | | | 0.14 | 3600 | 52.48 | 4.61 | 39.93 | 80 |
| 120B | 120×120×25 | | M | | 0.2 | 2500 | 69.32 | 3.2 | 35.53 | 130 |
| 12038L2 | 120×120×25 | | L | | 0.15 | 2000 | 95 | 3 | 35 | 260 |
| 120 | 120×120×38 | | M | | 0.3 | 3200 | 107.4 | 8.07 | 50.82 | 312 |
| 12038H2 | 120×120×38 | | H | | 0.8 | 5000 | 172 | 23 | 60 | 260 |
| 17251M2 | 172×150×51 | | | | 1.3 | 3000 | 202 | 11 | 52 | 610 |
| 20060M2 | 200×200×60 | | M | | 1 | 2500 | 408 | 17 | 62 | 935 |

① Speed rating: M-Standard, L-Low, H-High.

② See P227 for details of applicable accessories iron mesh/filter, and P228 for details of louvers.

Please order as shown

| Model | Code | Dimension |
|-------|--------|-----------|
| ZHJ06 | 4010M2 | |
| ZHJ06 | 4028M2 | |
| ZHJ06 | 4010M2 | |

| Code | Type | Material | bearing |
|-------|-----------|----------|-----------------|
| ZHJ08 | Axial Fan | DC type | PBT double ball |

UL CE TUV



size: 80

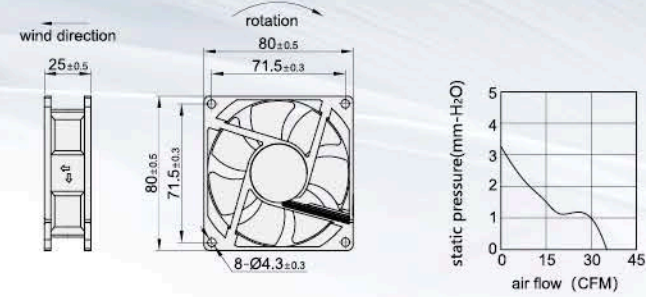

size: 92

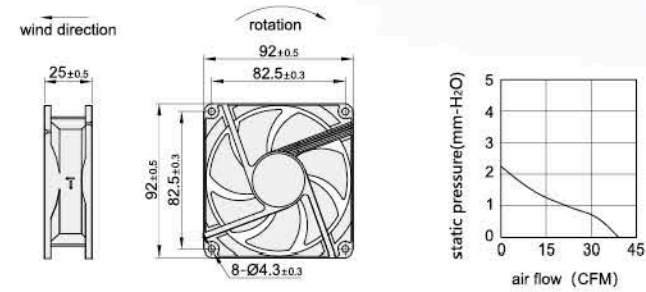

size: 120

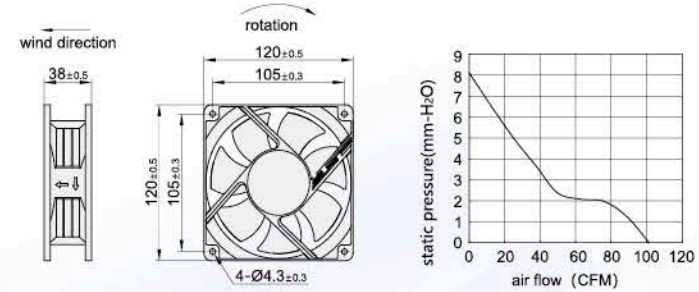

Perspective standard: first view

| Model | Length, width and height (mm) | Input Voltage | Power (W) | Current (A) | Rotational Speed (RPM) | Air volume (CFM) | Wind pressure (mm-H2O) | Noise (Db[A]) | Weight (g) |
|--------------|-------------------------------|---------------|-----------|-------------|------------------------|------------------|------------------------|---------------|------------|
| ZHJ08 | 80×80×25 | DC24V | 1.92 | 0.08 | 2700 | 34.6 | 3.1 | 28 | 47 |
| | 92×92×25 | | 1.2 | 0.05 | 2100 | 37 | 2.39 | 25 | 85 |
| | 120×120×38 | | 2.88 | 0.12 | 2300 | 101.4 | 8.1 | 38 | 260 |

① See P227 for details of applicable accessories iron mesh/filter, and P228 for details of louvers.

Please order as shown

| Model | Code | Dimension |
|-------|------|-----------|
| ZHJ08 | 80 | |
| ZHJ08 | 80 | |

| Code | Type | Material | bearing |
|-------|-----------|----------|-------------|
| ZHJ26 | Axial Fan | DC type | PBT |
| | | | double ball |

CE UL TUV



Features

- Add sensor output function on the basis of ordinary DC fan.
- Fan rotation/stop status or fan speed output can be monitored.
- Fan speed can be adjusted by PWM control.

size: 60

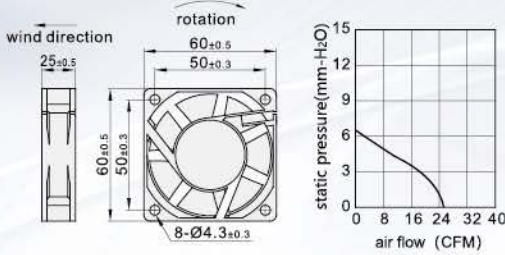

size: 80

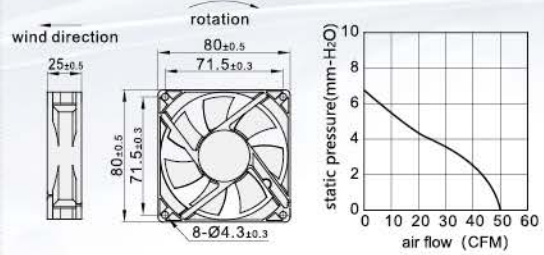

size: 92

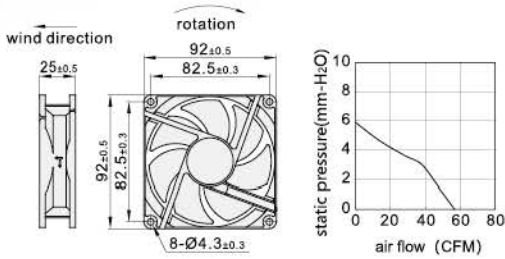

size: 120

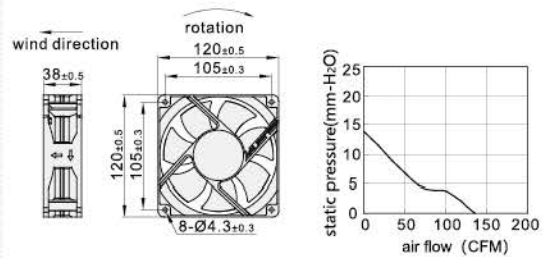

size: 172

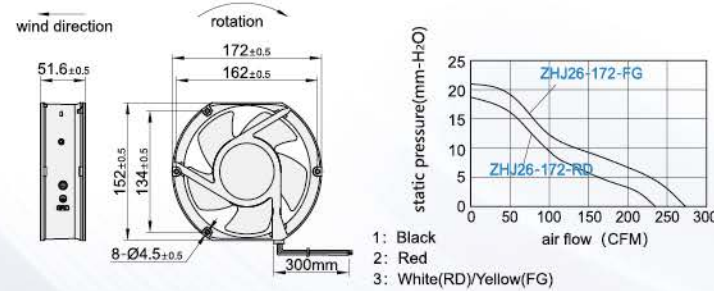

Wiring Diagram

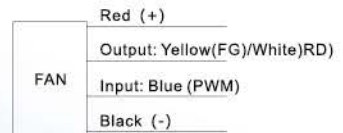

Perspective standard: first view

| Model | | Output Function | Length, width and height (mm) | Accessories | Input Voltage | Rotational speed control function | Rotational Speed (RPM) | Air volume (CFM) | Noise (Db[A]) | Weight (g) |
|-------|-----------|--|-------------------------------|---|---------------|-----------------------------------|-------------------------------------|------------------|---------------|------------|
| Code | Dimension | | | | | | | | | |
| ZHJ26 | 60 | RD (Turn/Stop status output) | 60×60×25 | Iron Mesh ZHJ42 Filter mesh ZHJ41 or Blinds ZHJ43 | DC24V | PWM Control Mode | 5000 | 25.6 | 40 | 57 |
| | 80 | | 80×80×25 | | | | 4300 | 50.5 | 40 | 76 |
| | 92 | FG (Rotational speed output) | 92×92×25 | | | | 3200 | 56.8 | 38 | 79 |
| | 120 | | 120×120×38 | | | | 2900 | 123.2 | 44 | 260 |
| | 172 | RD (Turn/Stop status output) FG (Rotational speed output) | 152×172×51.6 | | | | None (3-wire, no blue PWM input) | 3000 | 235.5 | 54 |
| | | | | | 3500 | 263 | 57 | 610 | | |

See P227 for details of applicable accessories iron mesh/filter, and P228 for details of louvers.

Please order as shown

| Model | | Output Function |
|-------|-----------|------------------------------|
| Code | Dimension | |
| ZHJ26 | 60 | RD (Turn/Stop status output) |
| | 80 | FG (Rotational speed output) |

ZHJ26—60—RD